



Man in the Aircraft Flight Control System

R. Jalovecký^{1*}

¹ *Department of Aerospace Electrical Systems, University of Defence, Brno, Czech Republic*

The manuscript was received on 05 January 2009 and was accepted after revision for publication on 3 February 2009.

Abstract:

The article deals with one of possible approaches how to create an alternate model of pilot behaviour in the process of aircraft flight control, especially in the situation when a repression of fast oscillations of aircraft is eligible. Therefore the analysis and simulation of human behaviour with respect to automatic regulation view is introduced. Results of the simulation of his response to the input pulse and results of the integration of a human pilot to the circuit of absorbing fast oscillations are also presented.

Keywords:

Aircraft automatic control, autopilot, oscillation damper, aircraft, Matlab, Simulink

1. Introduction

The process of defining an alternative regulation block diagram which represents the behaviour of human pilot is very extensive and complex. It basically represents the terminal part of the theoretical analysis in the case of its application into the loop of flight control. The main reason for this is instability of relevant “parameters” and of “time constants” of person, which has been analyzed as one of existing blocks in the regulation loop.

When some considerations in a possible pilot structure as typical elements in control systems were mentioned and described elsewhere [1], they usually took into account only orientation aspects. In current practice when modern simulation systems are implied, slightly different applications and considerations are specified [2,3]. Therefore, a probable structure of human (car driver and/or pilot controlling flight of the aircraft) as element of the aircraft flight control system is described in the paper.

* *Corresponding author: Department of Aerospace Electrical Systems, University of Defence, Kounicova 65,662 10 Brno, Czech Republic, tel.: +420 973 445 217, fax: +420 973 445 279, E-mail: rudolf.jalovecky@unob.cz*

2. Characteristics of Human as a Part of Automatic Regulation Loop

Human pilot's ability to control aircraft supposes the processing of a group of very heterogeneous information, and their conversion to corresponding activities of active segments of the aircraft (control stick, pedals, engine thrust). All this information which could be changed includes different levels of information, which are often in inadequate ratio between useful signal and noise. Pilot's ability to receive and evaluate this information is very restricted, especially in the flight situation, when he must acquire this information (no interrupted flight, complicated acrobatic flight, etc.). Generally, the time stress is the biggest pilot's enemy, hence a lack of time for processing all this information. As a result of this, a delay, sometimes large, between input signal and corresponding pilot's reaction, emerges.

In this situation, it means during a flight control of aircraft, a pilot is a part of closed flight control loop. When analyzing characteristics of the loop, it is necessary to take into account all pilot's characteristics (positive or negative), which could affect control process.

Among his positive characteristics, the ability of reaction (sometimes with some delay) with respect to unexpected situations, influences or events which could immediately affect the flight mode is one of the most important ones.

As for his negative characteristics, it is possible to mention restricted ability to simultaneously process a large amount of information, and/or rapidly changing information, influence of tiredness performance decrease, distraction attention, all in use together with other tasks, etc.

When [2] is applied, the human pilot's characteristics in a system of control can be described by a relatively complicated block diagram presented in Fig.1. Generally it is not possible to create one universal model of human which can fully characterize his dynamic properties in various tasks in the process of flight control.

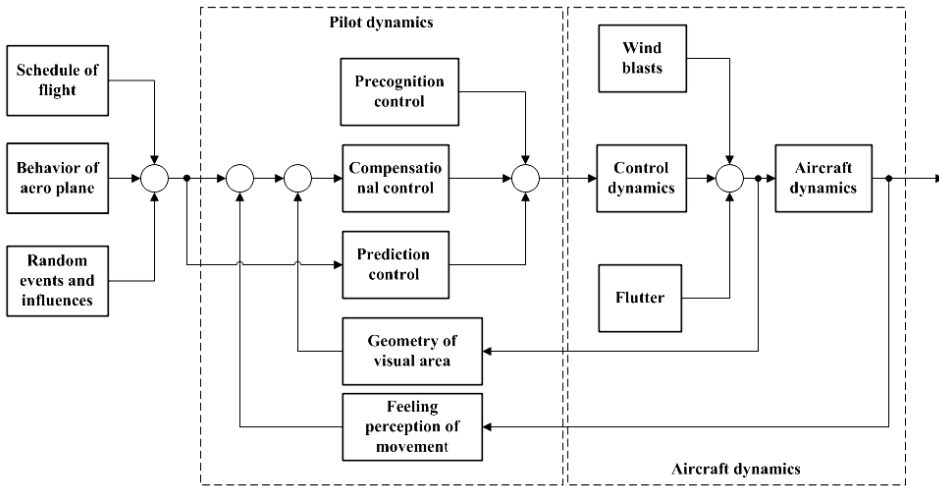

Fig. 1 Block scheme of pilot's integration to the control system

Dynamics of human behaviour expressed in Fig. 1 can be demonstrated by simpler block diagram in Fig. 2. There are three mutually bounded "blocks" here. As inputs are used sensory organs, from which detected information is transferred to the

central nervous system. Impulse average speed diffusion in nervous system is in the range from 5 to 125 m/s. When this situation is transmitted to the elements of automatic regulation, we can define this feature as transmission delay. Time of reaction depends on the level of inner voltage, immediate pilot state, or eventually on another influence. Characteristics of sensory organs are in practice characterized by the sensitivity limits, ability of adaptation and mutual cooperation. After information processing an instruction is given to muscle activity on arms or legs to deflect aircraft control surfaces.

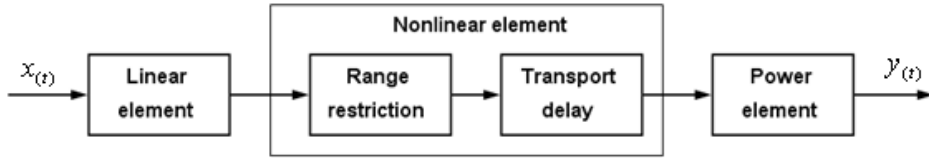

Fig. 2 Functional model of pilot's behaviour

To obtain the required flight character, the pilot can apply three different types of regulators [2]:

- *Prediction regulator* which keeps required flight character on the basis of information obtained from eye area and sense perception, from which the pilot can obtain necessary information on aircraft movements.
- *Feedback regulator* which is formed by visual information and feeling perceptions with respect to requested flight mode.
- *Precognitive regulator*, which evokes learned manoeuvre from memory, i.e. clear sequence of steer movements, which consequently brings up requested aircraft movement.

In all cases of the analysis of the human incorporated into the system of flight control it is necessary take into consideration that all his properties could change in time and hence they are strongly depending on his actual state, mental state of mind, tiredness and ability adaptation to current situation. In this situation a long-time routine, study, training, etc. are substantially helpful.

Due to the large amount of parameters, it is not easy to compile the mathematic model of human behaviour. Therefore, in different experiments described in literature, a simplified linear model is used (but it is not so true, it should be used from the point of view of restriction output quantity only) with transmission delay characterized by transmission function [1]

$$F_{(p)} = \frac{Y_{(p)}}{X_{(p)}} = K \frac{(T_3 p + 1)}{(T_1 p + 1)(T_2 p + 1)} e^{-tp} \quad (1)$$

Where:

$Y_{(p)}$ – Output signal

$X_{(p)}$ – Input signal

K – Increasing of force on the steers in relation to their deflection (from 1 to 100)

- T_1 – Reaction time constant, i.e. reaction ability to rate of change of input signal (5 to 20 s) (prediction time constant)
- T_2 – Dynamics properties of the pilot power members components (0.1 to 0.2 s) (neuromuscular time constant)
- T_3 – Integrating time constant, i.e. pilot's ability to realize varying activity (0.2 to 1 s)
- t – Transmission delay (0.1 to 0.4) (time of pilot reaction).

This most complete model of dynamics properties of human pilot will be denoted in following simulation as Pilot type – “A”.

When eliminating the inertial component T_2 , simplified transmission function, often referred to as the Gross model of man's dynamics, is obtained [1, 2]

$$F_{(p)} = \frac{Y_{(p)}}{X_{(p)}} = K \frac{(T_3 p + 1)}{(T_2 p + 1)} e^{-tp} \quad (2)$$

This simplified model will be denoted in the following as Pilot type – “B”.

Among the easiest human pilot activities one can consider processes, where man does not realize any “integration” or “derivation” of the input signal, but performs only function as amplifying element with dynamics of power member. With respect to this consideration, one obtains the easiest transmission function of human pilot dynamics [1]

$$F_{(p)} = \frac{Y_{(p)}}{X_{(p)}} = K \frac{1}{(T_2 p + 1)} e^{-tp} \quad (3)$$

This model will be denoted as Pilot type – “C”.

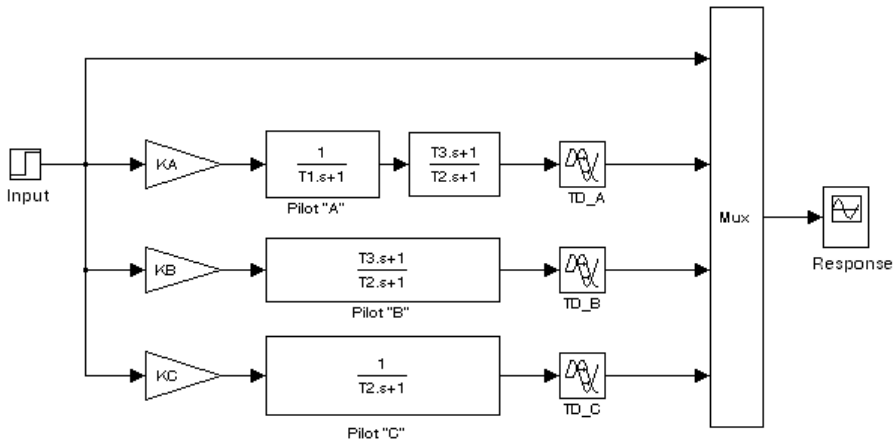

Fig. 3 Block scheme of man characteristics simulation

With mentioned “types” models of human pilot's dynamics, the simulation of responses to single input impulse according to Fig. 3 has been provided.

The obtained response and used values of particular time constants are expressed in Fig. 4. These graphs express a large difference in response to “unit” pulse for various descriptions of dynamics properties of a man.

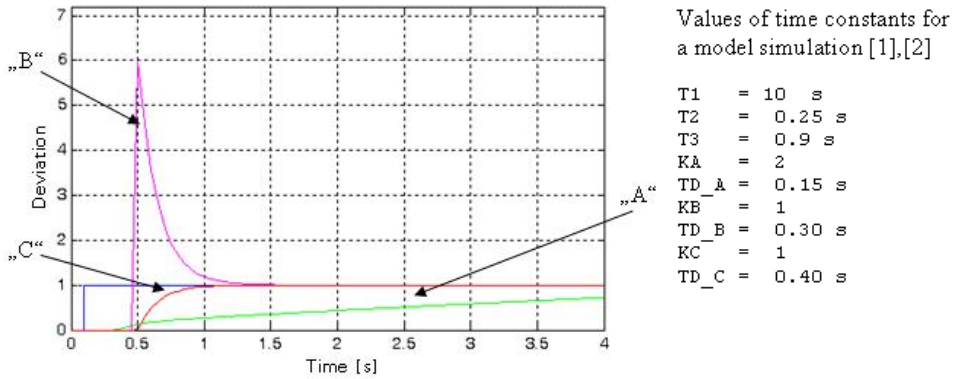

Fig. 4 Response of dynamic models of human

3. Pilot Integration into the Loop for Fast Oscillations Absorbing

To find characteristics of human-aircraft regulation loop, one can use the simulation model of aircraft movement in longitudinal axis [4], which presents fast oscillations of aircraft. Exactly these oscillations represent the biggest danger for airframe and they also generate very uncomfortable feeling for crew. Coefficients n_{ij} [4] used in this model characterize well-controllable combat aircraft which means aircraft with low stability. Fig. 5 represents typical response characteristics to unit input signal, which is identical when the human-pilot is inserted into the loop for fast oscillation damping. Pilot’s properties then gradually present an approximation to his dynamics parameters simulated in chapter 2.

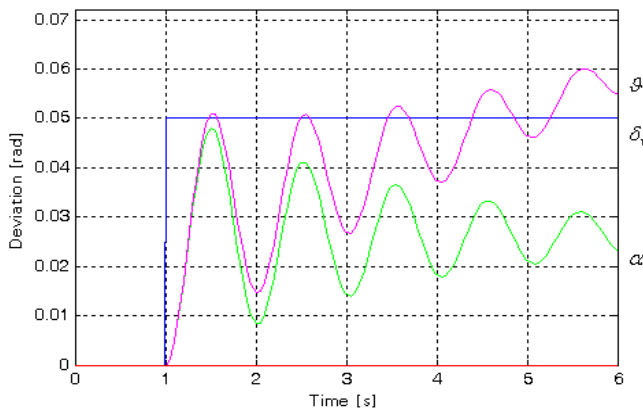

Fig. 5 Fast oscillations of aircraft in longitudinal axes – without damping

Now we put the human-pilot into feedback in the system of „fast oscillations damping“. The theory of automatic control in application for aircraft control clearly supposes that as input signal for „oscillation damper“ a first derivation has to be made, i.e. angular velocity of such a position angle around which one wants to damp fast oscillations. This is not possible when a human is used in the loop because he is not able to immediately react to arising angular speed (or his reaction is very slow). But he is able to recognize beginning phase of angular movement, consequently the moment of increasing, or maybe the moment when the maximum change of positional angle was reached. As an input signal for human pilot abilities simulation as regulator for fast oscillations damping, a concrete positional angle can be only used.

Fig. 6 mentions a simple block diagram of human behaviour simulation integrated in the system of aircraft fast oscillation damping. A block named “Aircraft – fast oscillations” presents a simulation model for fast oscillations of aircraft. (This block will be used for longitudinal movement in the next chapter). Then a Block “Pilot” presents simulations of human (subsequently types “A”, “B”, and “C”) which will intervene into steer deviation caused by signal generated at input (for longitudinal movement, it represents the step change of elevator deflection).

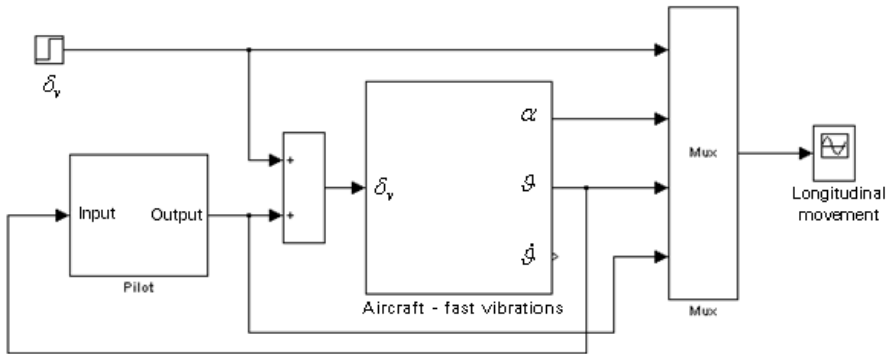

Fig. 6 Block diagram for fast oscillation damping simulation with dynamics characteristics of man - pilot using

Individual „responses“, which represent a behaviour of pilot-aircraft system, or their linear movement only, can suggest possibilities of pilot’s behaviour when fast oscillations are damped during the aircraft movement.

3.1. Fast Aircraft Oscillations Damping when use Integration Pilot Type “A”

Mathematic expression of “transmission function” for pilot type “A” (Eq. 1) can be transformed into block diagram MATLAB-SIMULINK system (see Fig. 7). Since “Parameters of individual block” were mentioned in Fig. 4, the transport delay can be realized by block “Transport delay”. The value of “Time delay” is put into this block as a coefficient TD_A.

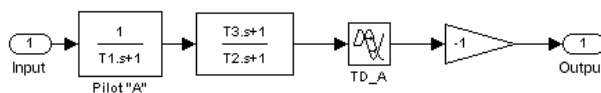

Fig. 7 Block diagram of dynamic properties of human pilot type “A”

Fig. 8 displays a response of system pilot-aircraft in fast oscillations damping mode in longitudinal axis. From this simulation, one can suppose, that pilot is ready to solve the task of fast oscillation damping. By competent intervention to the control stick and by periodic “wobbling”, he is able to decrease the value of oscillations to lower value.

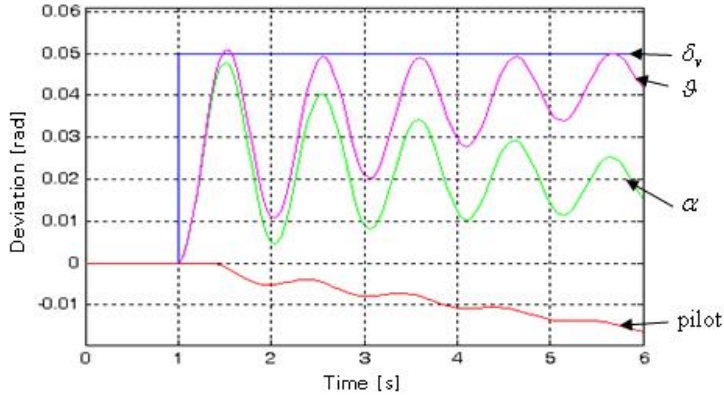

Fig. 8 Results of fast oscillation damping simulation with human pilot type “A”

3.2. Fast Aircraft Oscillations Damping when Integration Pilot Type “B” is used

One can also transform a mathematic expression of “transmission function” of the pilot type “A” (Eq. 2) into block diagram MATLAB-SIMULINK system (Fig. 9) and set there parameters mentioned in Fig. 4. The value of “Time delay” is put into this block as a coefficient TD_B.

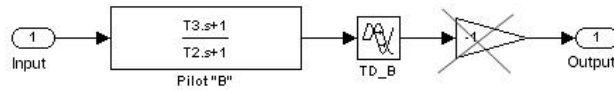

Fig. 9 Block diagram of dynamic properties of human pilot type “B”

Fig. 10 shows a displayed response of system pilot-aircraft when negative feedback “turns” to the positive one (see deleted block in Fig. 9). In this case a negative feedback response of system is too large (deflection should be 300 rad). It means that this simulation has no practical sense.

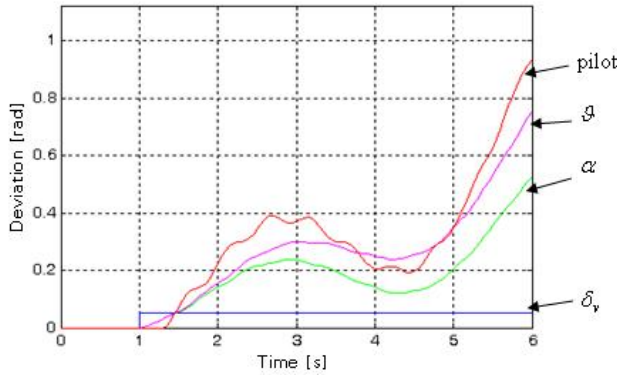

Fig. 10 Results of fast oscillations damping simulation with human pilot type “B”

In principle, this simulation is not so effectual because the setting of deviation values of the elevator between 45 and 50° is not possible on a real aircraft. For such a solution, the response of system is too large and it cannot respond to methods of small deviation, and consequently to the proposed linearized model of aircraft, and also to the linearized model of human behaviour.

3.3. Fast Aircraft Oscillations Damping when Integration Pilot Type “C” is used

Mathematic expression of “transmission function“ of the third pilot type “C” (Eq. 3) can also be transformed into a block diagram (Fig. 11). By using parameters mentioned in Fig. 4, a transport delay is contained in coefficient TD_C.

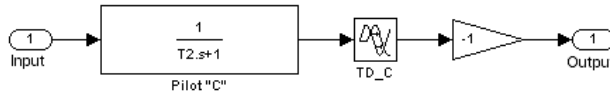

Fig. 11 Block diagram of dynamic properties of human pilot type “C”

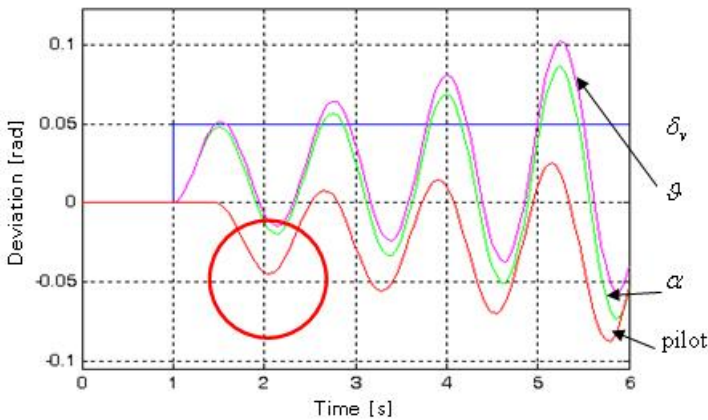

Fig. 12 Results of fast oscillations damping simulation with human pilot type “C”

Fig. 12 shows the response of pilot-aircraft system. It is a typical response there which is very near to the real situation. By the influence of pilot's time delay reaction to the stimulation (the change of longitudinal movement of aircraft) the pilots begin to "correct" longitudinal deflection in the moment when the longitudinal position change of aircraft is in the same phase as elevator deviation (see the circle in Fig. 12). This activity continuously results in increasing aircraft longitudinal deflection.

4. Conclusion

In the article, a possible way of pilot's behaviour modelling when he tried to reduce or totally damp fast oscillations of aircraft is investigated. It has been demonstrated that by orientation simulation, a pilot would be able to inhibit part of the airplane's oscillations, however it is necessary to be aware of all what he would manage simultaneously (move the control stick in both directions – to damp longitudinal and transversal - side oscillations) and this in opposite phase with respect to oscillations, and so to attend their damping. Pilot would not be able to realize other, considerably more complicated and heterogeneous missions. For these reasons, the attendance of many automatic systems for aircraft's oscillations damping and also for other tasks in flight control realization is very important.

Summary of Abbreviations, used in Picture

J - Aircraft pitch angle

\dot{J} - Pitch rate

α - Angle of attack

d_v - Elevator deflection

Pilot - Response pilot

References

- [1] ŽIHLA, Z. *Automatic control of aerospace*, Part 1 (in Czech). Provisional textbook, U-1220/I, Brno : Vojenská akademie, 1987. 395 p.
- [2] HAVLÍKOVÁ, M. Models of driver's behaviour (in Czech). *Elektrorevue*, 2004, vol. 22. [online] [cited 2009-1-20]. Available from: <http://www.elektrorevue.cz/clanky/04022/index.html>.
- [3] HAVLÍKOVÁ, M. Human reliability and hazard of his failure in systems MMS (in Czech). *Automatizace*, 2006, vol. 49, no. 7-8, p. 461-462.
- [4] JALOVECKÝ, R. *Onboard systems flight control I* (in Czech). Brno : University of Defence, 2008. 82 p.

Acknowledgement

The work presented in this paper has been supported by the Ministry of Defence of the Czech Republic (Research Plan No. MO0FVT 0000403).